

14. FINAL DRIVE

COMPONENT LOCATION	14-2	PINION GEAR REMOVAL/SHIM REPLACEMENT	14-13
SERVICE INFORMATION	14-3	FINAL GEAR CASE BEARING REPLACEMENT	14-15
TROUBLESHOOTING.....	14-6	PINION GEAR INSTALLATION.....	14-20
FINAL DRIVE REMOVAL.....	14-7	RING GEAR INSTALLATION	14-23
FINAL DRIVE INSPECTION.....	14-8	FINAL GEAR CASE ASSEMBLY.....	14-26
FINAL GEAR CASE SEPARATION.....	14-11	FINAL DRIVE INSTALLATION.....	14-27
RING GEAR REMOVAL /SHIM REPLACEMENT.....	14-12		

COMPONENT LOCATION

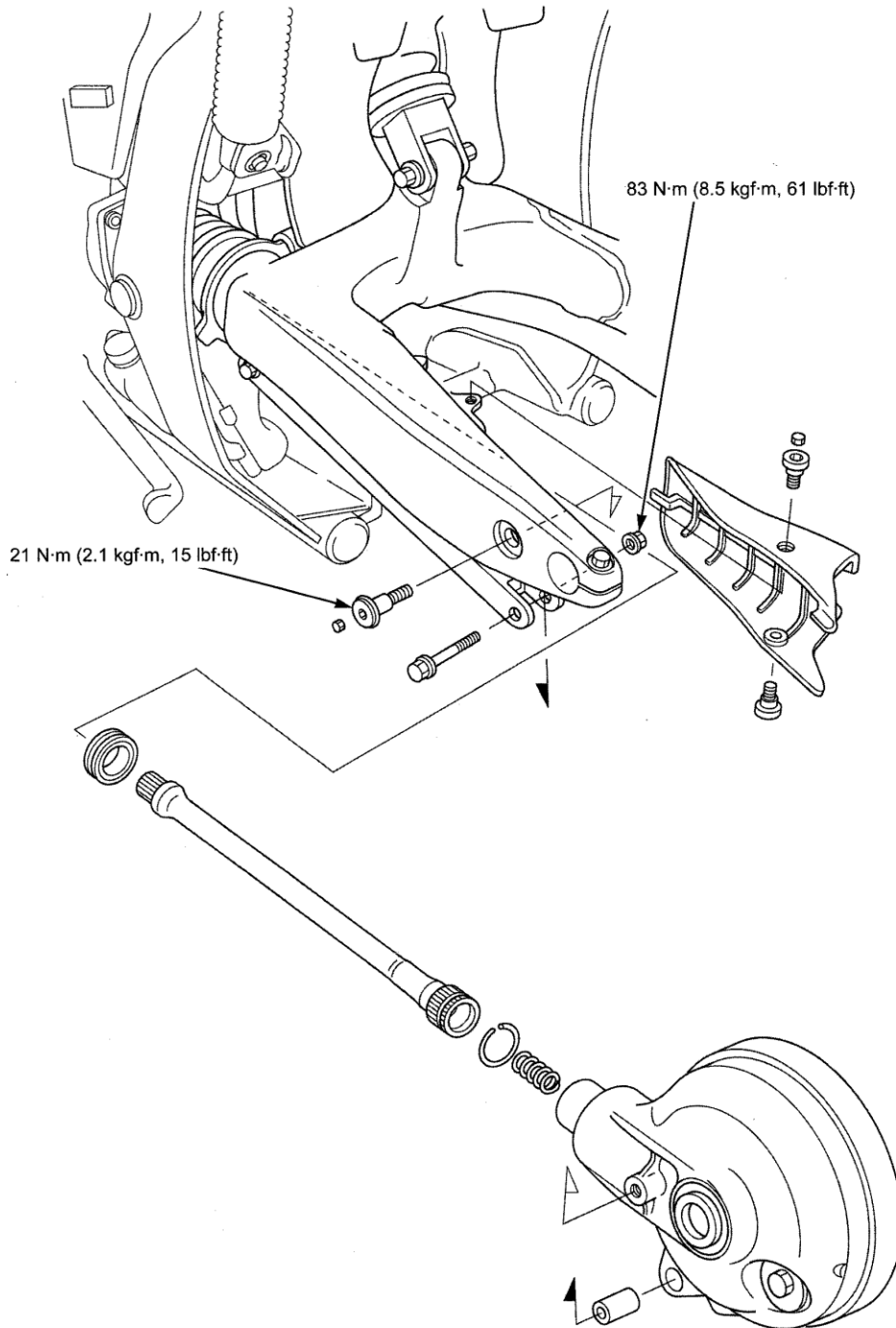

SERVICE INFORMATION

GENERAL

- The final drive gear assembly and final drive shaft must be removed together.
- Perform the gear contact pattern and backlash inspection whenever you replace the bearings, gears or gear case. The extension lines from the gear engagement surfaces should intersect at one point.
- Protect the gear case with a shop towel or soft jaws while holding it in a vise. Do not clamp the gear case too tightly or it could be damaged.
- Replace the ring and pinion gears as a set.

SPECIFICATIONS

Unit: mm (in)





ITEM	STANDARD	SERVICE LIMIT
Recommended final drive oil	Hypoid gear oil, SAE #80	–
Final drive oil capacity	At draining	130 cm ³ (4.4 US oz, 4.6 Imp oz)
	At disassembly	170 cm ³ (5.7 US oz, 6.0 Imp oz)
Final drive gear backlash	0.05 – 0.15 (0.002 – 0.006)	0.30 (0.012)
Backlash difference between measurements	–	0.10 (0.004)
Ring gear-to-stop pin clearance	0.30 – 0.60 (0.012 – 0.024)	–
Final drive gear assembly pre-load	0.2 – 0.4 N·m (0.02 – 0.04 kgf·m, 0.1 – 0.3 lbf·ft)	–

TORQUE VALUES

Pinion retainer	147 N·m (15.0 kgf·m, 108 lbf·ft)	
Pinion retainer lock tab bolt	10 N·m (1.0 kgf·m, 7 lbf·ft)	
Pinion joint bolt	147 N·m (15.0 kgf·m, 108 lbf·ft)	Apply locking agent to the threads.
Dust guard plate bolt	10 N·m (1.0 kgf·m, 7 lbf·ft)	
Final gear case cover bolt (10 mm)	63 N·m (6.4 kgf·m, 46 lbf·ft)	Apply locking agent to the threads.
Final gear case cover bolt (8 mm)	26 N·m (2.7 kgf·m, 19 lbf·ft)	
Torque arm nut	83 N·m (8.5 kgf·m, 61 lbf·ft)	U-nut
Final gear case assembly layout bolt	21 N·m (2.1 kgf·m, 15 lbf·ft)	

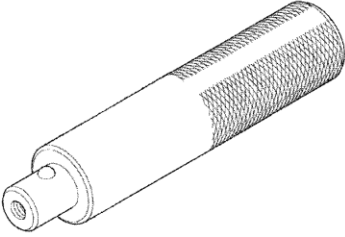
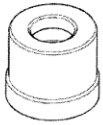
FINAL DRIVE

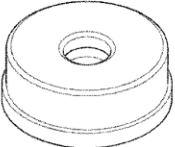
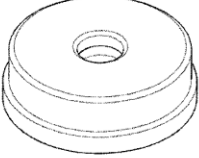
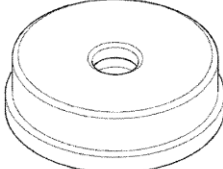
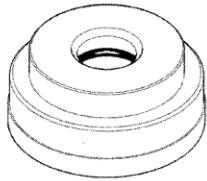
TOOLS

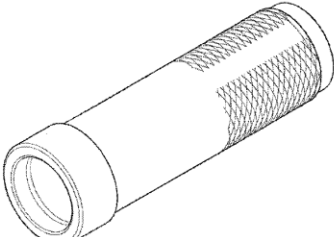
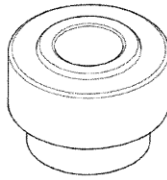
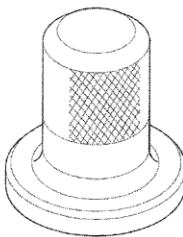
<p>Driver 07749-0010000</p> 	<p>Attachment, 28 x 30 mm 07946-1870100</p> 	<p>Attachment, 32 x 35 mm 07746-0010100</p> 
<p>Attachment, 52 x 55 mm 07746-0010400</p> 	<p>Attachment, 62 x 68 mm 07746-0010500</p> 	<p>Attachment, 72 x 75 mm 07746-0010600</p> 
<p>Installer ball race, 65 mm 070MF-MEC0100</p> 	<p>Pilot, 20 mm 07746-0040500</p> 	<p>Pilot, 25 mm 07746-0040600</p> 
<p>Driver, 40 mm I.D. 07746-0030100</p> 	<p>Attachment, 25 mm I.D. 07746-0030200</p> 	<p>Oil seal driver, 67.5 mm 07948-SC20200</p> 

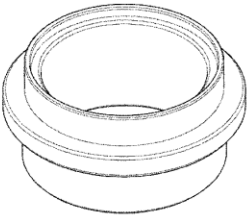
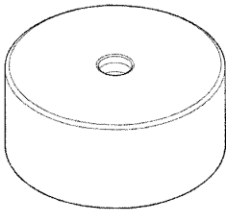
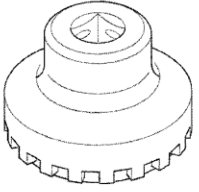
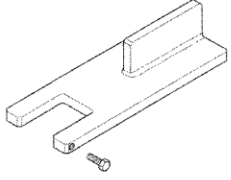
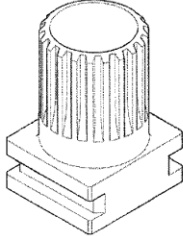
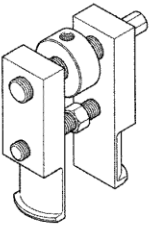
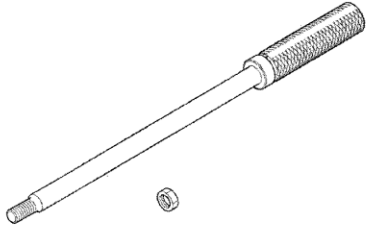
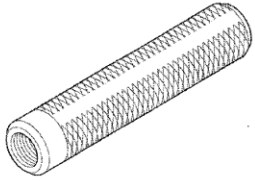
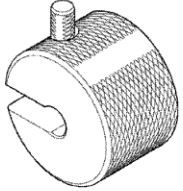
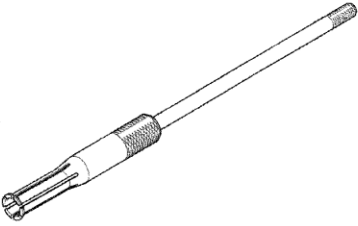
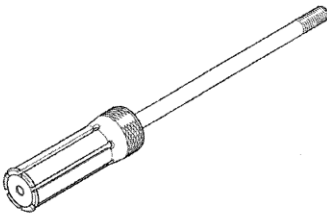
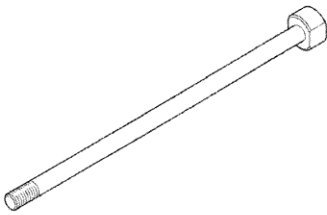
<p>Oil seal driver 070MF-MEG0300</p> 	<p>Oil seal driver attachment, 80 x 96 mm 07ZAD-PNA0100</p>  <p>or 07VAD-P8A010A (U.S.A. only)</p>	<p>Retainer wrench, 60 mm 070MA-MFR0100</p> 
<p>Pinion holder plate 070MB-0010110</p> 	<p>Pinion holder attachment, 41.5 070MB-0010120</p> 	<p>Ball race remover 07YAC-0010102</p> 
<p>Ball race remover shaft 07JAC-PH80200</p>  <p>Not available in U.S.A.</p>	<p>Remover handle 07936-3710100</p> 	<p>Remover weight 07741-0010201</p>  <p>or 07936-371020A (U.S.A. only)</p>
<p>Bearing remover, 20 mm 07936-3710600</p> 	<p>Bearing remover, 35 mm 07936-3710400</p> 	<p>Sliding shaft 07736-0010101</p> 

FINAL DRIVE

Oil seal driver
07947-SB00100

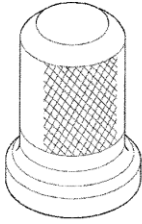

or 07947-SB0A100 (U.S.A. only)

TROUBLESHOOTING

Excessive noise

- Worn or scored ring gear shaft and driven flange
- Scored driven flange and wheel hub
- Worn or scored drive pinion and splines
- Worn pinion and ring gears
- Excessive backlash between pinion and ring gears
- Oil level too low
- Worn or damaged pinion gear and/or pinion joint splines

Oil leak

- Clogged breather
- Oil level too high
- Damaged seals
- Loose case cover bolts

Excessive rear wheel backlash

- Worn drive shaft splines
- Excessive backlash between pinion and ring gears
- Worn driven flange and ring gear splines
- Excessive play in final drive case bearings
- Worn drive shaft, universal joint and/or pinion joint splines
- Excessive play or worn universal joint bearing

FINAL DRIVE REMOVAL

NOTE:

- When disassembling the final gear case, drain the final drive oil (page 4-19).

Remove the rear wheel (page 16-6).

Do not reuse the socket bolts. Remove the rubber cap, socket bolts and drive shaft cover.

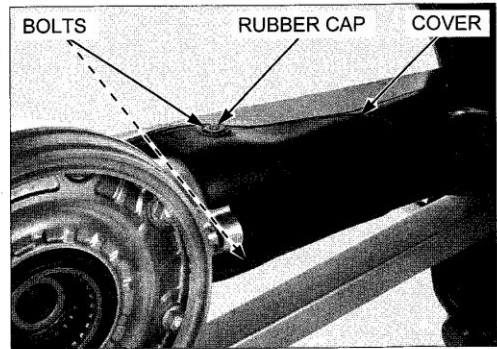

Remove the nut, bolt and torque arm.

Remove the torque arm bushing.

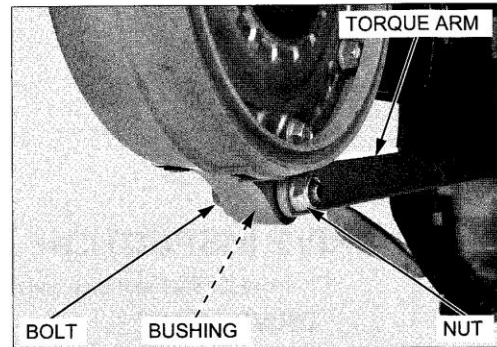

Remove the rubber cap, layout bolt and final gear case assembly with the drive shaft.

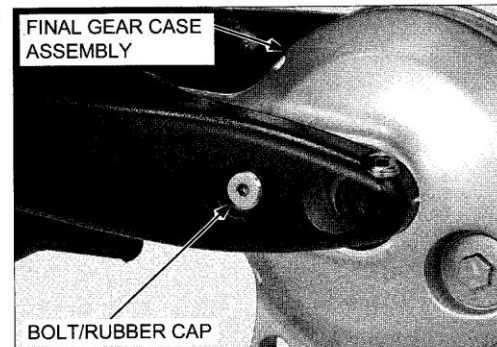

Separate the drive shaft from the gear case by gently turning the drive shaft and pulling it.



FINAL DRIVE

Remove the collar.

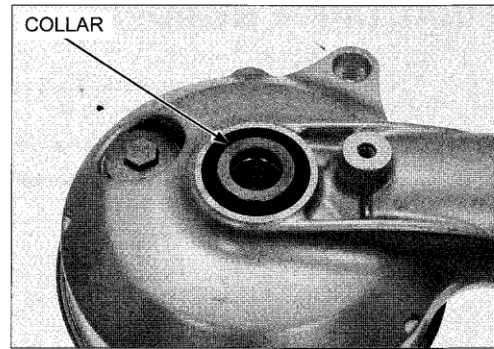

Remove the spring, oil seal and stopper ring from the drive shaft.

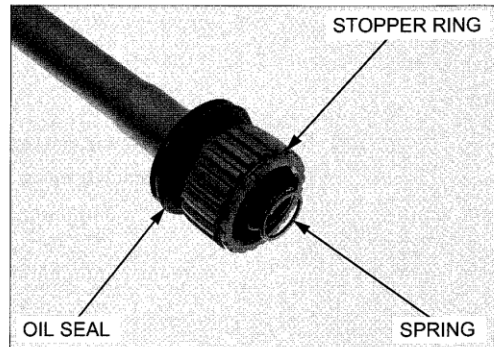

FINAL DRIVE INSPECTION

Remove the final gear case and drive shaft (page 14-7).

DRIVE SHAFT

Check the splines of the drive shaft for damage or wear.

If the splines of the drive shaft are damaged, check the following:

- Universal joint splines
- Pinion joint splines

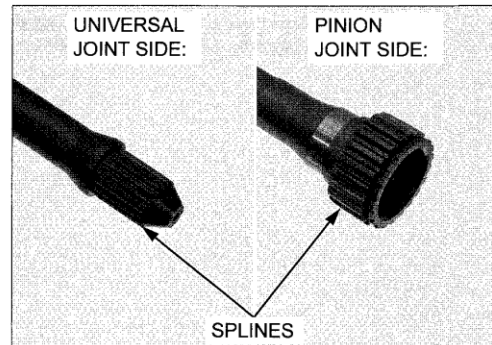

OPERATION

Turn the pinion joint and check that the pinion and ring gears turn smoothly and quietly without binding.

If the gears do not turn smoothly or quietly, the gears and/or bearing may be damaged or faulty. They must be checked after disassembly; replace the faulty parts/assemblies as required.

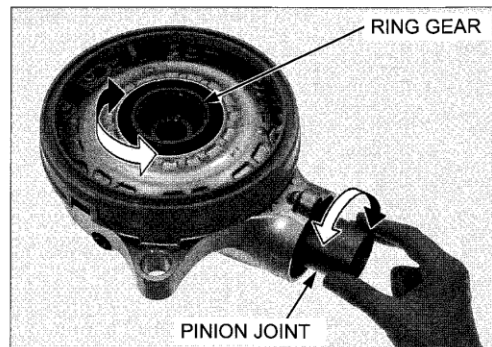

BACKLASH

NOTE:

- Perform the backlash inspection whenever you replace the pinion gear, ring gear, bearings and gear case.

Install the special tools and set them in a vise.

Install the special tool onto the gear case and into the pinion joint to hold the pinion gear.

TOOLS:

- Pinion holder plate 070MB-0010110
- Pinion holder attachment, 41.5 070MB-0010120

Remove the oil filler cap.

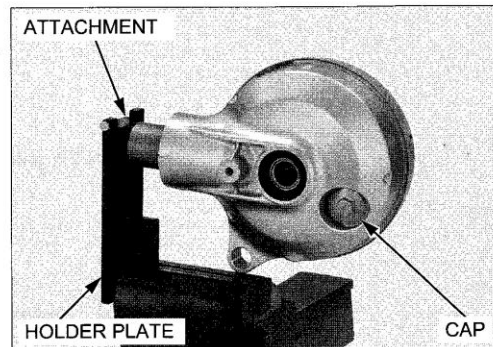

Set a horizontal type dial indicator on the ring gear, through the oil filler hole.

Hold the final gear case and turn the ring gear back and forth to read the backlash.

- STANDARD:** 0.05 – 0.15 mm (0.002 – 0.006 in)
- SERVICE LIMIT:** 0.30 mm (0.012 in)

Remove the dial indicator and special tool.
Turn the ring gear 120° and measure the backlash.
Repeat this procedure once more.
Compare the difference of the three measurements.

- SERVICE LIMIT:** 0.10 mm (0.004 in)

If the difference in measurements exceeds the service limit, it indicates that the bearing is not installed squarely, or the case is deformed.
Inspect the bearings and case.

If the backlash is excessive, replace the ring gear shim with a thicker one.
If the backlash is too small, replace the ring gear shim with a thinner one.

RING GEAR SHIMS:

- A: 1.82 mm (0.072 in)
- B: 1.88 mm (0.074 in)
- C: 1.94 mm (0.076 in)
- D: 2.00 mm (0.079 in) – Standard
- E: 2.06 mm (0.081 in)
- F: 2.12 mm (0.083 in)
- G: 2.18 mm (0.086 in)
- H: 2.24 mm (0.088 in)
- I: 2.30 mm (0.091 in)

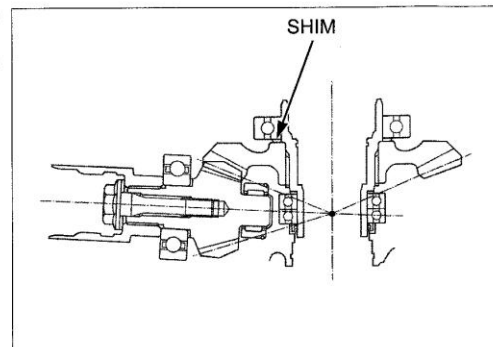
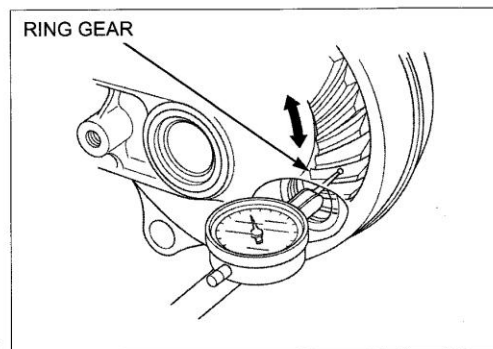

For ring gear shim replacement (page 14-12).

GEAR TOOTH CONTACT PATTERN

Description of the tooth:

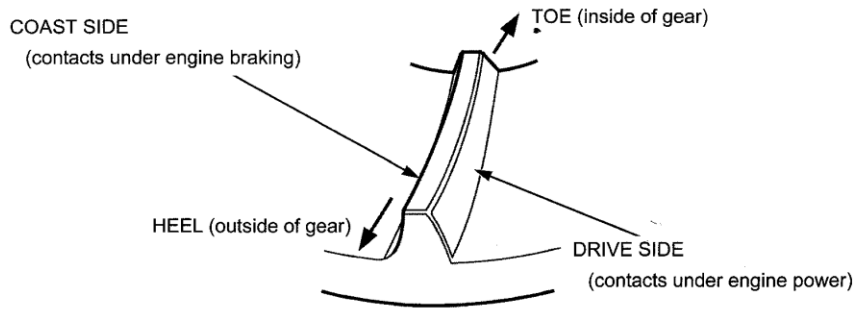

NOTE:

- Perform the contact pattern check whenever you replace the pinion gear, ring gear, bearings and gear case.

Separate the final gear case (page 14-11).

Keep dust and dirt out of the case and cover.

Clean the sealing material off the mating surfaces of the gear case and cover, being careful not to damage them.

Apply a thin coat of Prussian Blue to the pinion gear teeth.

Install the wave washer.

Install the gear case cover onto the gear case.

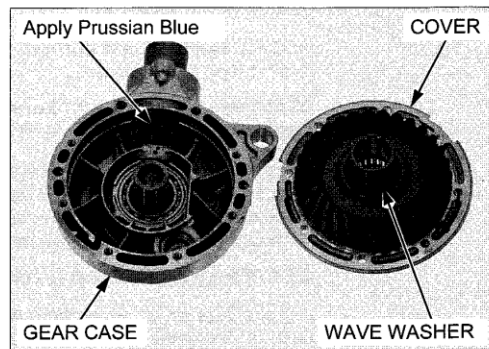

Install and tighten the final gear case cover bolts in a crisscross pattern in several steps until the cover evenly touches the gear case.

Tighten the 10 mm bolts to the specified torque in several steps alternately.

TORQUE: 63 N-m (6.4 kgf-m, 46 lbf-ft)

Tighten the 8 mm bolts to the specified torque in a crisscross pattern in several times.

TORQUE: 26 N-m (2.7 kgf-m, 19 lbf-ft)

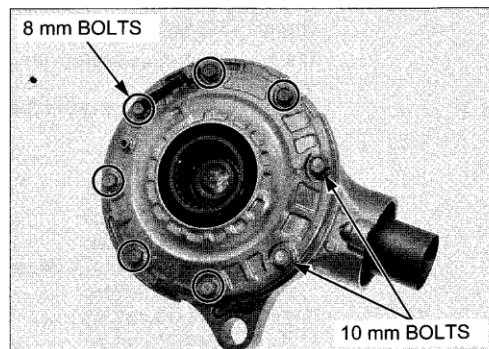

Remove the oil filler cap.

Rotate the ring gear several times in both directions of rotation.

Check the gear tooth contact pattern through the oil filler hole.

The pattern is indicated by the Prussian Blue applied to the pinion gear.

Contact is normal if the Prussian Blue is transferred to the approximate center of each tooth and slightly towards the face.

If the patterns are not correct, remove and change the pinion shim with a suitable one (page 14-13).

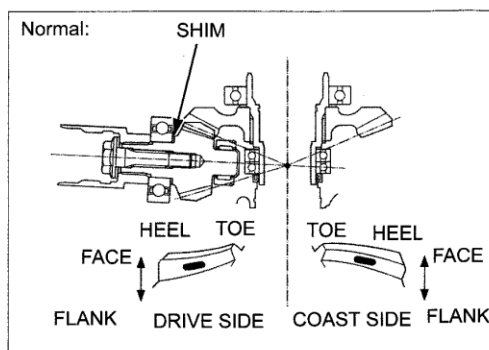

Replace the pinion gear shim with a thicker one if the contact pattern is too high, toward the face.

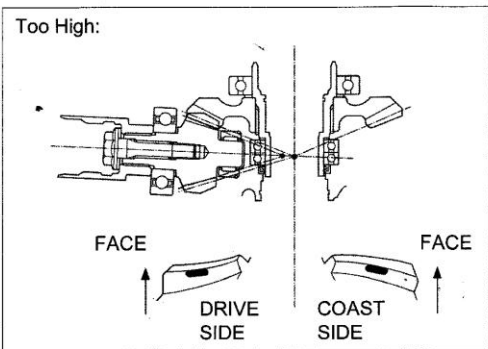

Replace the pinion gear shim with a thinner one if the contact pattern is too low, toward the flank.

The patterns will shift about 1.5 – 2.0 mm (0.06 – 0.08 in) when the thickness of the shim is changed by 0.1 mm (0.004 in).

PINION GEAR SHIMS:

- A: 1.32 mm (0.052 in)
- B: 1.38 mm (0.054 in)
- C: 1.44 mm (0.057 in)
- D: 1.50 mm (0.059 in) – Standard
- E: 1.56 mm (0.061 in)
- F: 1.62 mm (0.064 in)
- G: 1.68 mm (0.066 in)

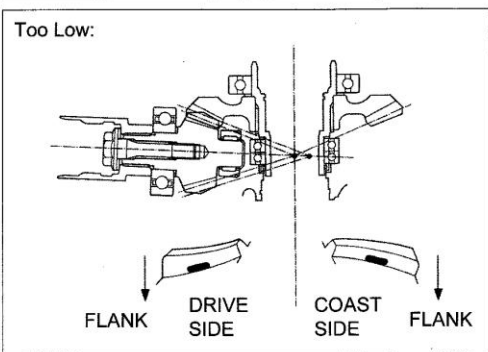

For pinion gear shim replacement (page 14-13).

FINAL GEAR CASE SEPARATION

Remove the final drive (page 14-7).

Remove the bolt and the dust guard plate by turning it counterclockwise.

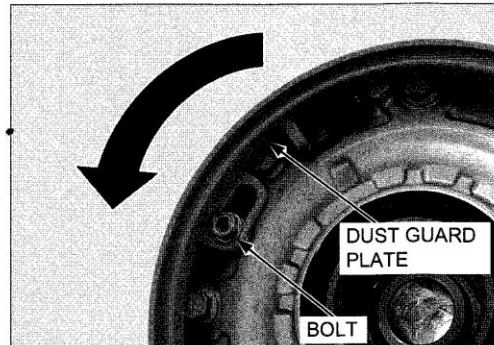

Loosen the final gear case cover 10 mm bolts and 8 mm bolts in a crisscross pattern in several steps and remove them.

Pry the gear case cover and remove it from the gear case.

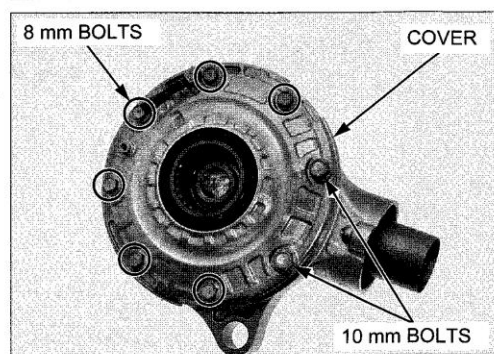

FINAL DRIVE

Remove the wave washer.

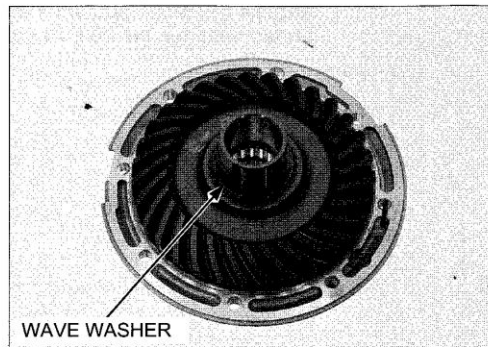

RING GEAR REMOVAL/SHIM REPLACEMENT

Separate the final gear case (page 14-11).

If the ring gear remained in the gear case cover, remove it as follows:

Support the gear case cover horizontally with the ring gear facing down and press the gear out using the special tool and hydraulic press.

TOOL:

Installer ball race, 65 mm 070MF-MEC0100

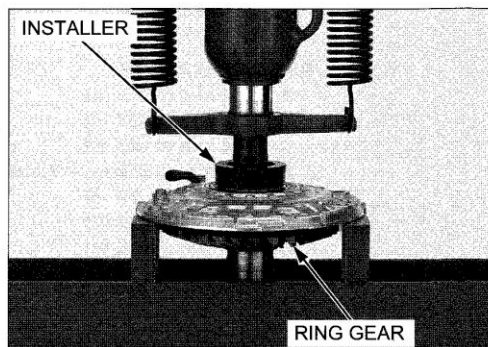

Remove the oil seal from the gear case cover.

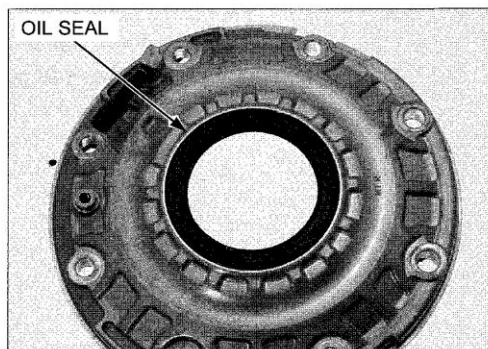

If the ring gear bearing remained in the gear case cover, remove it as follows:

Support the gear case cover horizontally and press the ring gear bearing out using the special tools and hydraulic press.

TOOLS:

Attachment, 72 x 75 mm 07746-0010600
Oil seal driver 070MF-MEG0300

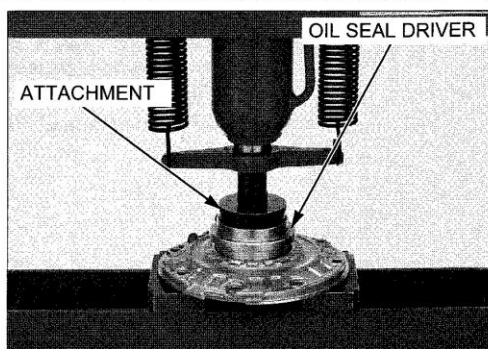

If the ring gear bearing remained on the ring gear, remove it as follows:

When adjusting the shim, this bearing replacement is not necessary.

Remove the ring gear bearing using a commercially available bearing puller. Remove the ring gear shim from the ring gear.

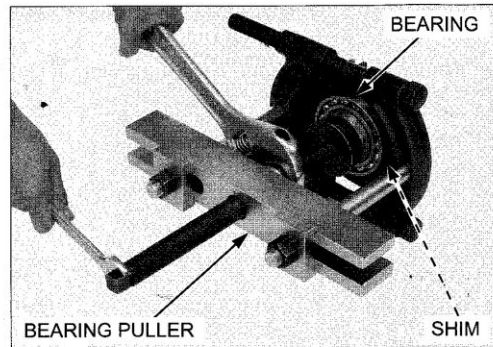

Remove the snap ring.

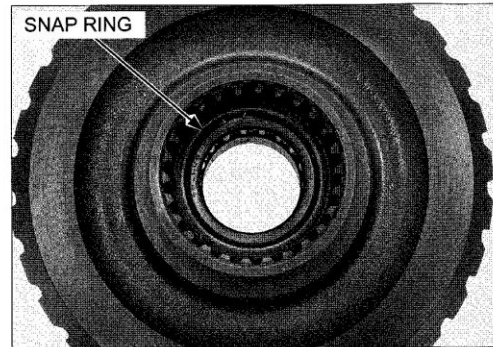

Remove the ring gear needle bearing using the special tools.

TOOLS:

Remover handle
Bearing remover, 35 mm
Remover weight

07936-3710100
07936-3710400
07741-0010201 or
07936-371020A
(U.S.A. only)

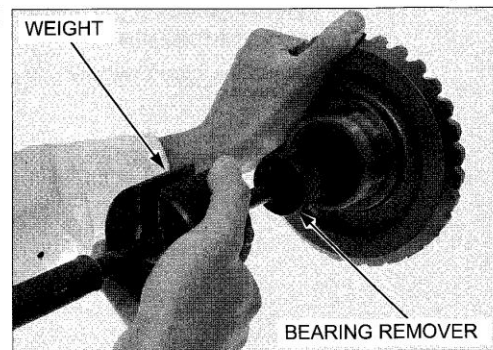

PINION GEAR REMOVAL/SHIM REPLACEMENT

Separate the final gear case (page 14-11).

Install the special tools and set them in a vise.

TOOLS:

Pinion holder plate 070MB-0010110
Pinion holder attachment, 41.5 070MB-0010120

Loosen the pinion joint bolt.

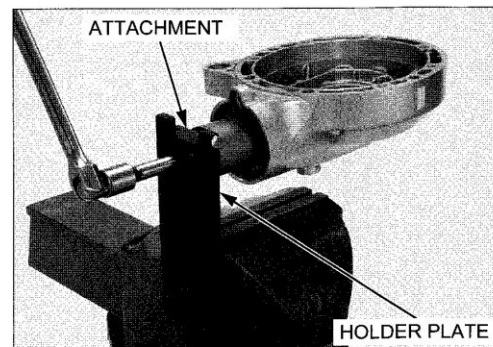

FINAL DRIVE

Remove the pinion joint bolt, washer and pinion joint.

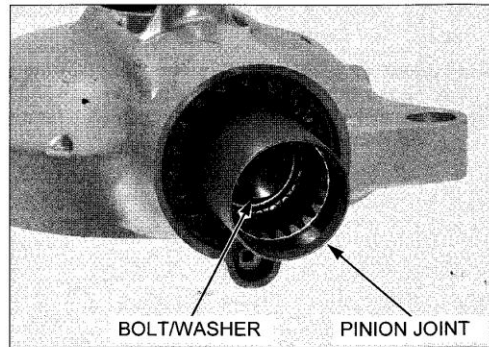

Remove the bolt and retainer lock tab.

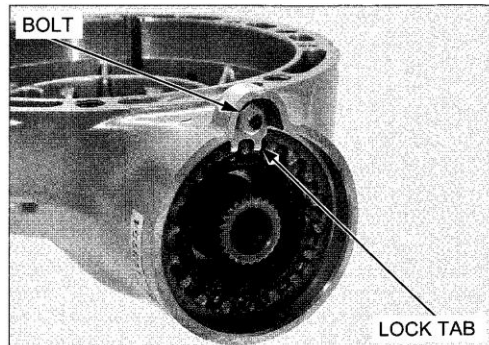

Set the gear case in a vise with a piece of wood or soft jaws to avoid damage.

Loosen the pinion retainer using the special tool and remove it.

TOOL:

Retainer wrench, 60 mm 070MA-MFR0100

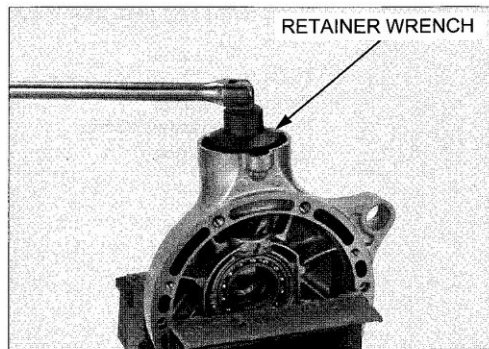

Remove the O-ring and oil seal from the pinion retainer.

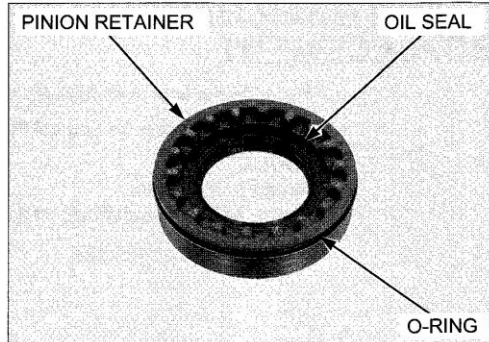

Install the special tools to the pinion gear shaft.

TOOLS:

Sliding shaft
Remover weight

07736-0010101
07741-0010201 or
07936-371020A
(U.S.A. only)

Pull the pinion gear assembly out of the gear case.

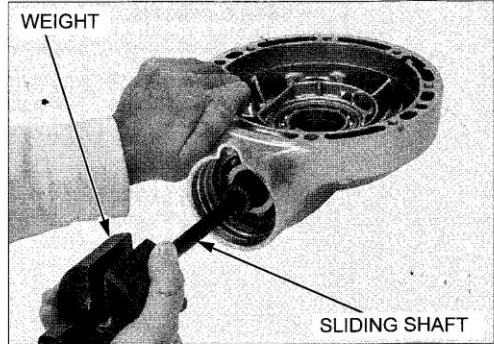

When adjusting the shim, this bearing replacement is not necessary. Remove the pinion gear bearing using a commercially available bearing puller. Remove the pinion gear shim from the pinion gear.

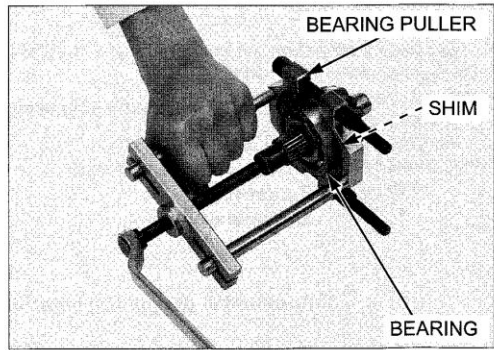

FINAL GEAR CASE BEARING REPLACEMENT

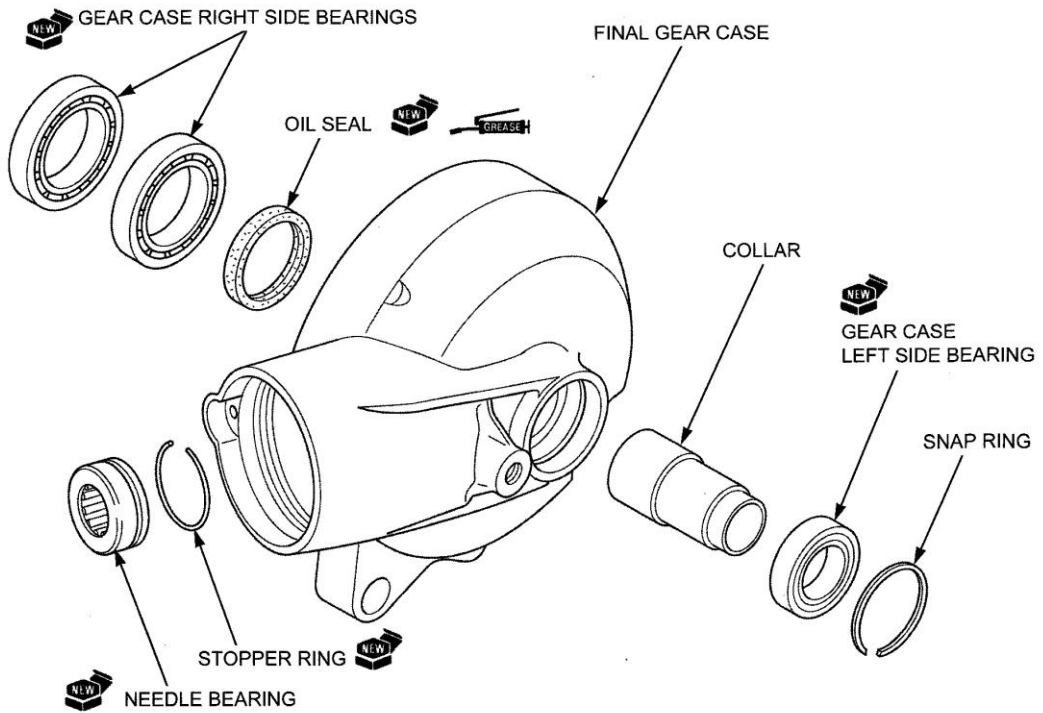

FINAL DRIVE

PINION GEAR NEEDLE BEARING

Remove the pinion gear (page 14-13).

Remove the stopper ring by rotating it until the end of the stopper ring appears in the access hole.

Strike gently near the end of the ring with a punch to bend the end upward.

Grasp the end of the ring with needle-nose pliers and pull the stopper ring out through the access hole.

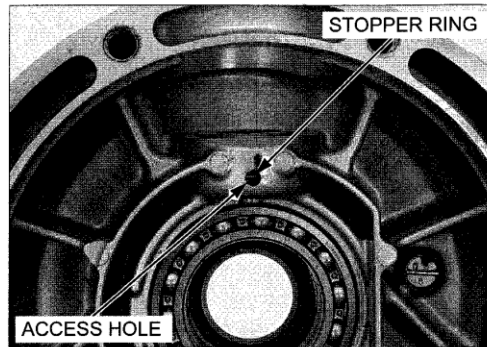

Be sure to wear heavy gloves when handling the heated final gear case. Using a torch to heat the gear case may cause warpage.

Heat the final gear case to 80°C (176°F) evenly using a heat gun.

Remove the needle bearing using the special tools.

TOOLS:

Bearing remover, 20 mm	07936-3710600
Remover handle	07936-3710100
Remover weight	07741-0010201 or 07936-371020A (U.S.A. only)

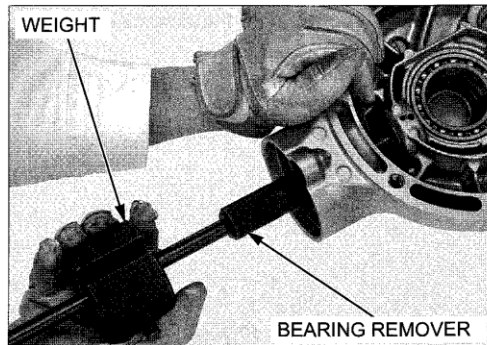

Remove the stopper ring from the needle bearing.

Install a new stopper ring into the groove of a new bearing securely.

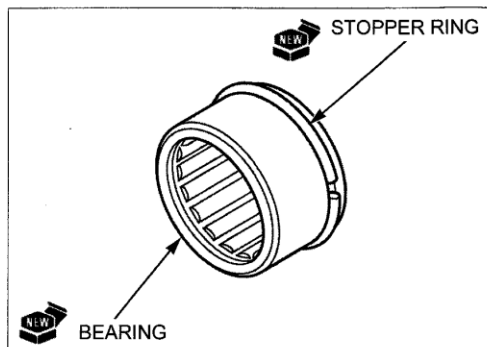

Be sure to wear heavy gloves when handling the heated final gear case. Using a torch to heat the gear case may cause warpage.

Place the needle bearing in a freezer.

Heat the final gear case to 80°C (176°F) evenly using a heat gun.

Remove the needle bearing from the freezer and drive it into the gear case using the special tools.

TOOLS:

Driver	07749-0010000
Attachment, 32 x 35 mm	07746-0010100
Pilot, 20 mm	07746-0040500

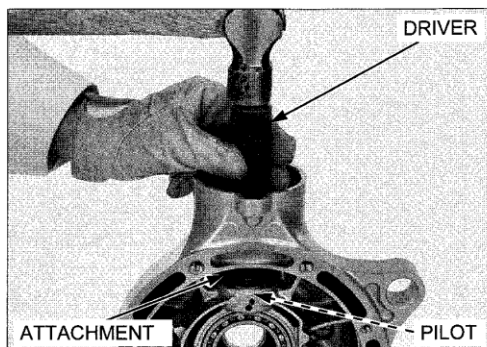

Make sure the stopper ring is securely set in the groove of the gear case.

Install the pinion gear (page 14-20).

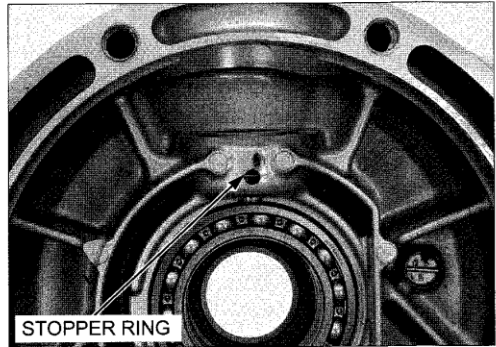

GEAR CASE BEARING

Separate the final gear case (page 14-11).

Remove the dust seal.

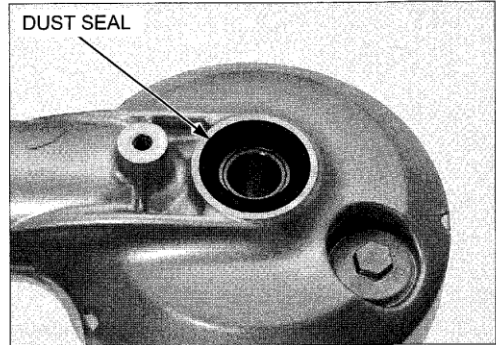

Drive out the collar using the special tools.

TOOLS:
 Driver 07749-0010000
 Attachment, 28 x 30 mm 07946-1870100
 Pilot, 25 mm 07746-0040600

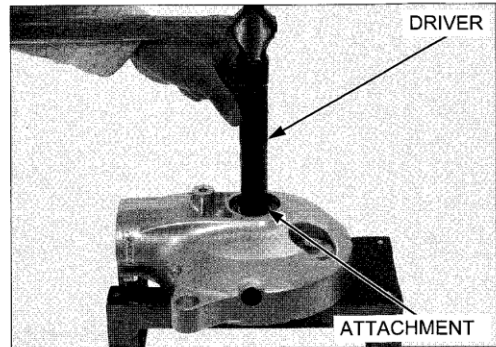

Remove the gear case right side bearings from the gear case using the special tools.

TOOLS:
 Ball race remover 07YAC-0010102
 Ball race remover shaft 07JAC-PH80200 not available in U.S.A.
 Remover weight 07741-0010201 or 07936-371020A (U.S.A. only)

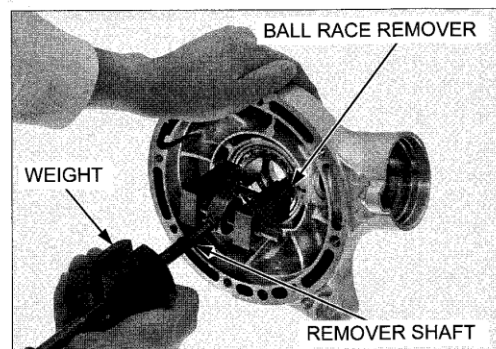

FINAL DRIVE

Remove the oil seal.

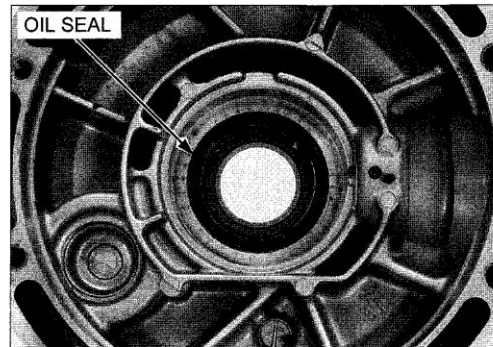

Remove the snap ring.

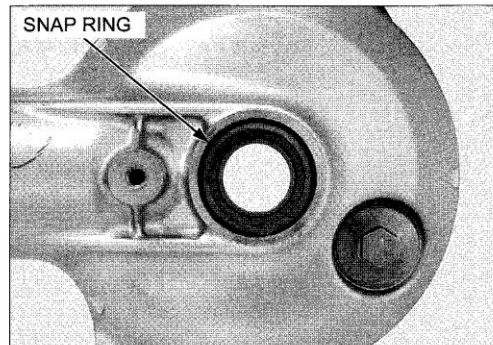

Remove the gear case left side bearing.

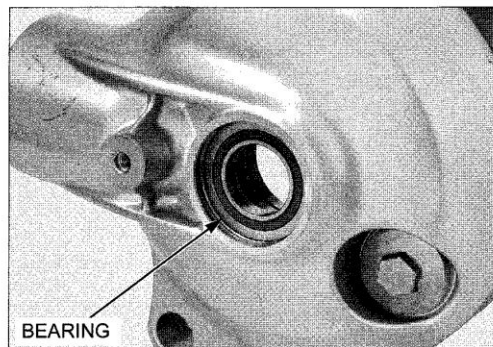

Apply grease to a new oil seal lip.

Drive in the oil seal into the gear case using the special tools.

TOOLS:

Driver

07749-0010000

Attachment, 62 x 68 mm

07746-0010500

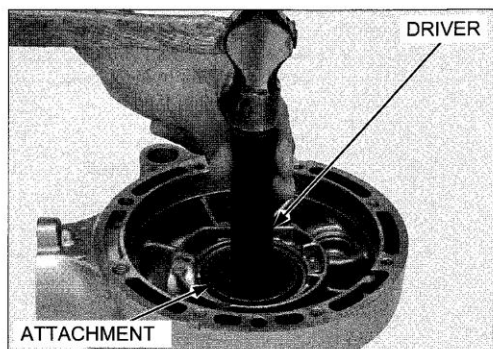

Drive in a new gear case right side bearings into the gear case using the special tools.

TOOLS:
Driver 07749-0010000
Attachment, 62 x 68 mm 07746-0010500

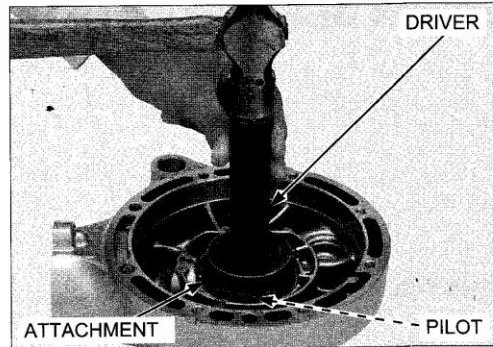

Drive in the collar to a new gear case left side bearing.

TOOLS:
Driver 07749-0010000
Attachment, 32 x 35 mm 07746-0010100
Pilot, 25 mm 07746-0040600

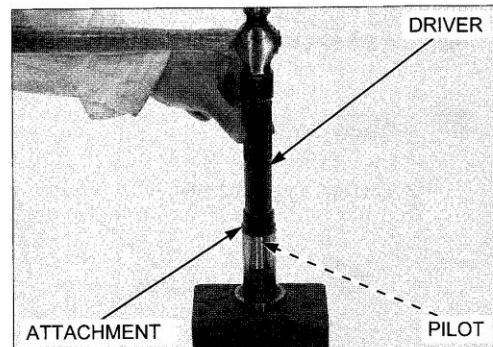

Drive in the gear case left side bearing with the collar using the special tools.

TOOLS:
Driver 07749-0010000
Attachment, 52 x 55 mm 07746-0010400
Pilot, 25 mm 07746-0040600

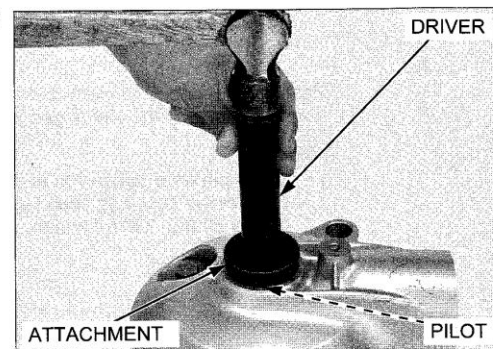

Install the snap ring.

- NOTE:**
- Install the snap ring with the chamfered edges facing the thrust load side.
 - Make sure the snap ring is seated in the groove.

Apply grease to a new dust seal lips and install it.

Assemble the final gear case (page 14-26).

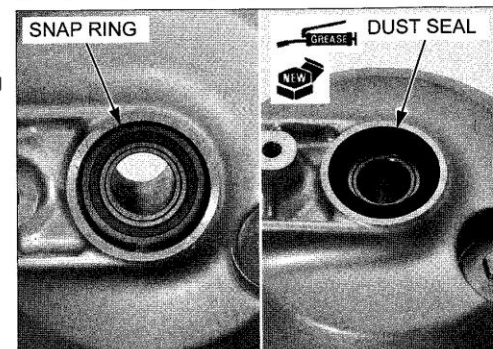

PINION GEAR INSTALLATION

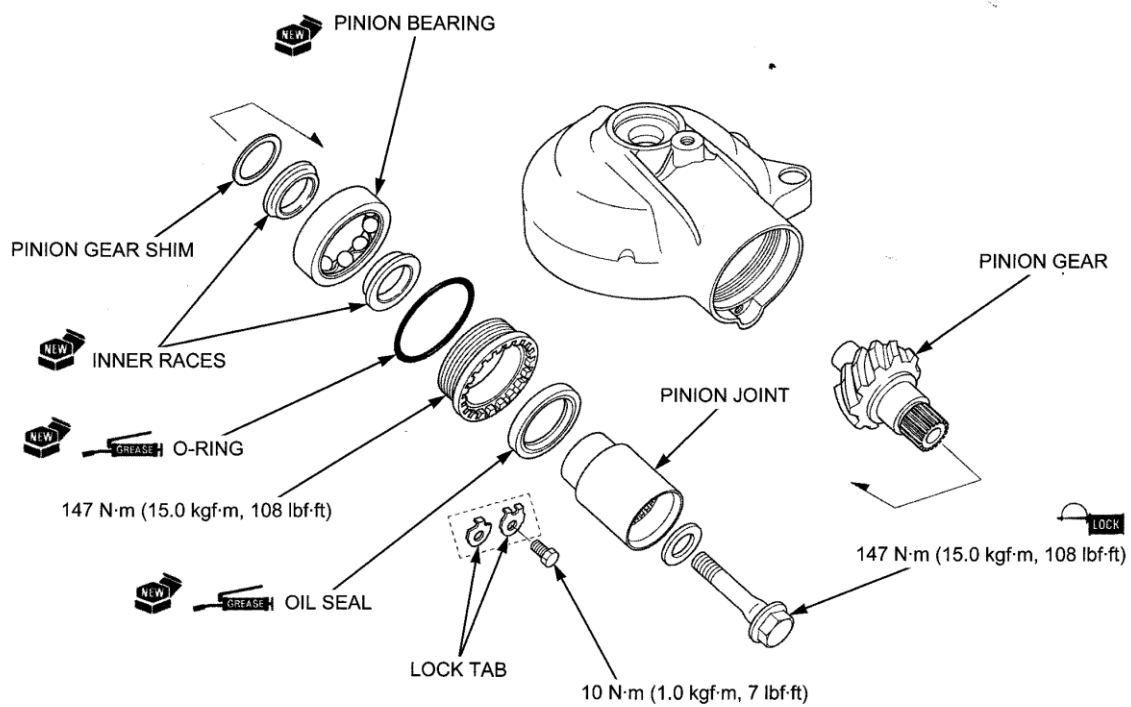

Install the pinion gear shim and new bearing (with new inner races) onto the pinion gear.

NOTE:

- When the gear set, pinion bearing, ring gear bearing and/or gear case has been replaced, use a 1.50 mm (0.006 in) thick shim for initial reference.

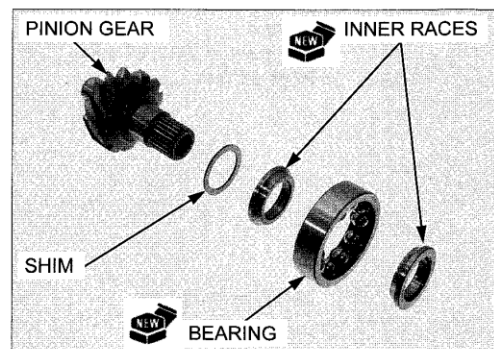

Drive in the bearing using the special tools.

TOOLS:

Driver, 40 mm I.D.

07746-0030100

Attachment, 25 mm I.D.

07746-0030200

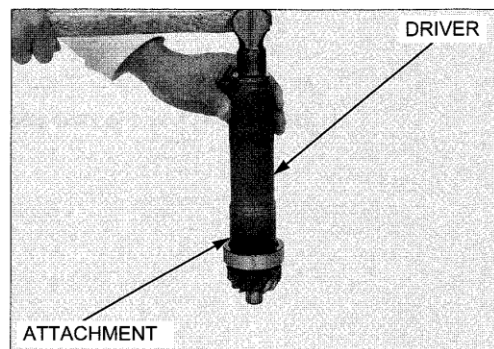

Drive in the pinion gear assembly into the gear case using the special tool.

TOOL:
Oil seal driver, 67.5 mm **07948-SC20200**

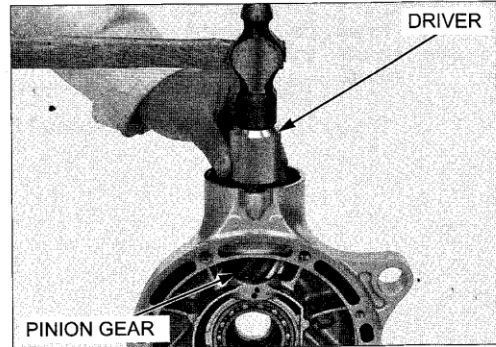

Drive in a new oil seal into the pinion retainer with the flat side facing down using the special tool.

TOOLS:
Driver **07749-0010000**
Attachment, 52 x 55 mm **07746-0010400**

Apply grease to a new oil seal lips.

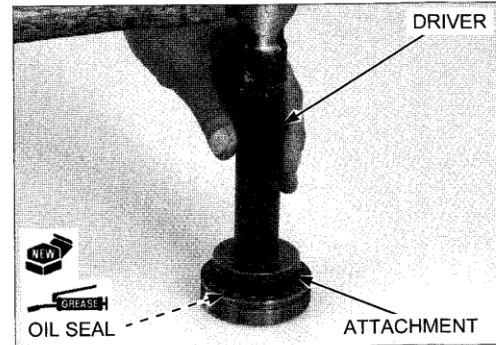

Apply grease a new O-ring and install it to the pinion retainer groove.

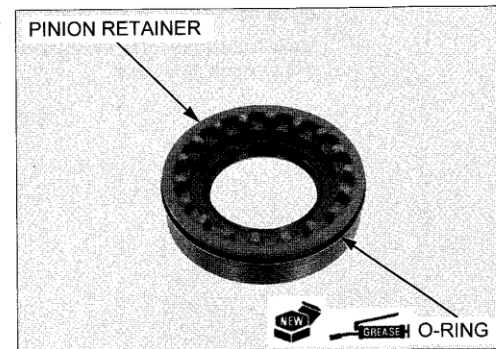

Set the gear case in a vise with a piece of wood or soft jaws to avoid damage.

Install the pinion retainer into the gear case.

Tighten the pinion retainer to the specified torque using the special tool.

TOOL:
Retainer wrench, 60 mm **070MA-MFR0100**

TORQUE: 147 N·m (15.0 kgf·m, 108 lbf·ft)

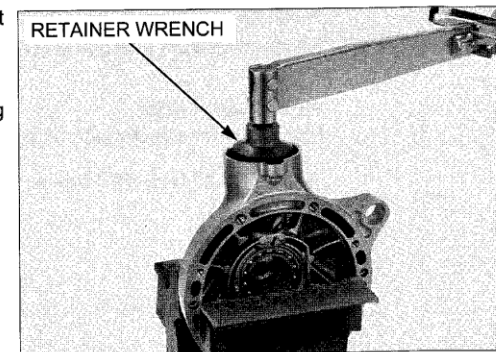

FINAL DRIVE

The lock tab is available in the two types (A and B) shown.

Install the lock tab, depending on the position of the pinion retainer grooves in relation to the lock tab and bolt.

Tighten the bolt to the specified torque.

TORQUE: 10 N·m (1.0 kgf·m, 7 lbf·ft)

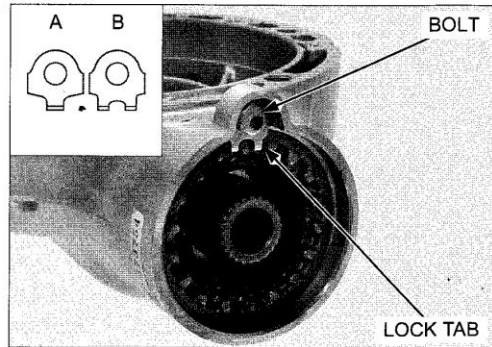

Install the pinion joint.

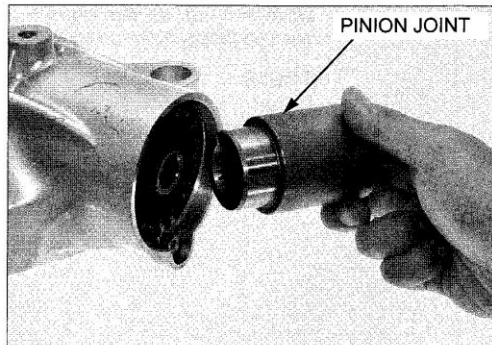

Install the washer to the pinion joint bolt.

Apply locking agent to the joint bolt threads and install it to the pinion gear shaft.

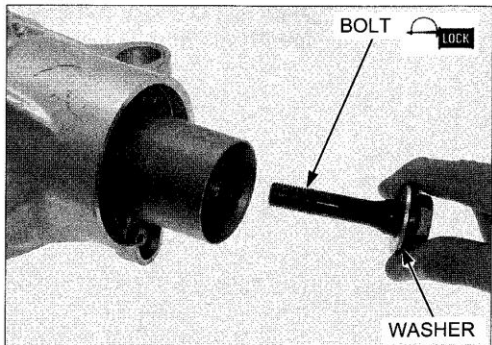

Install the special tools and set them in a vise.

Tighten the pinion joint bolt to the specified torque.

TOOLS:

Pinion holder plate 070MB-0010110

Pinion holder attachment, 41.5 070MB-0010120

TORQUE: 147 N·m (15.0 kgf·m, 108 lbf·ft)

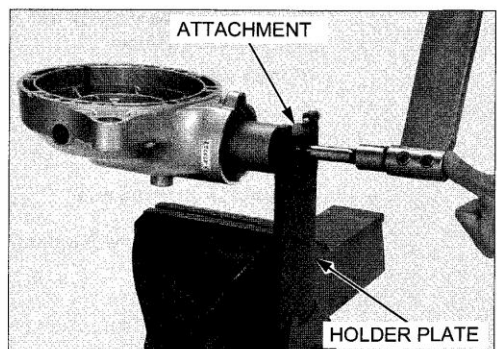

RING GEAR INSTALLATION

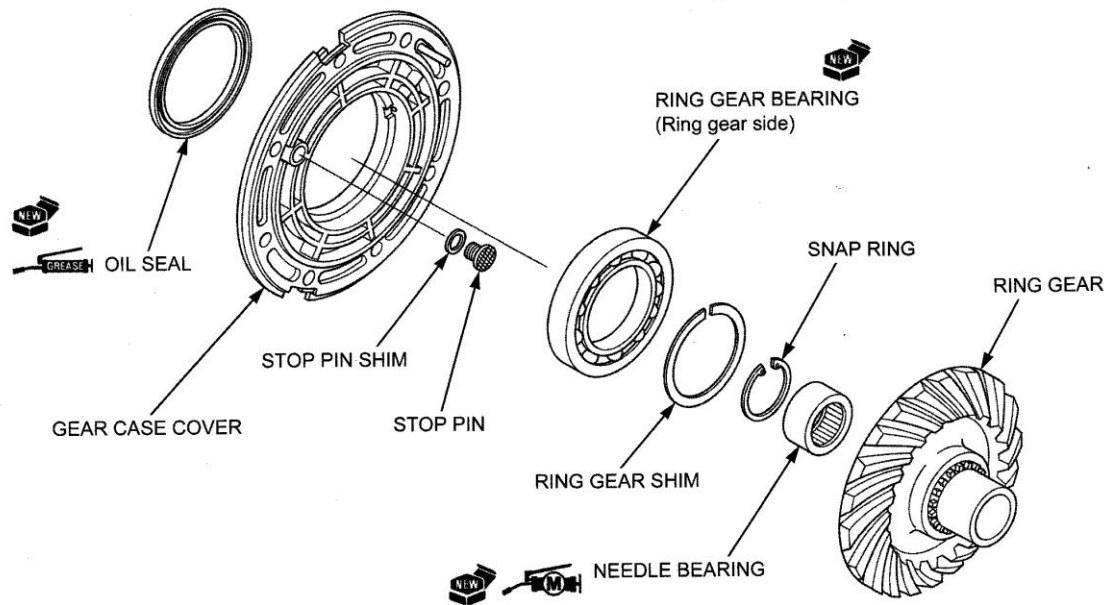

Blow open the passage of the gear case cover with compressed air.
Check the passage for clog, wear or damage.

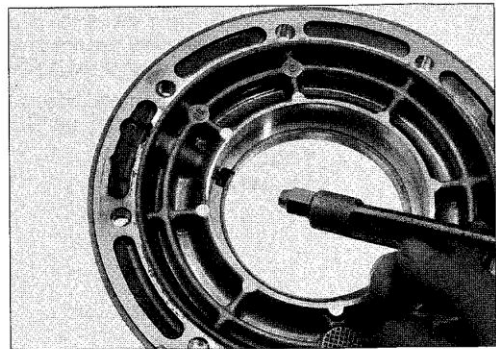

Apply molybdenum disulfide grease to a new ring gear needle bearing.

Support the ring gear horizontally and press the ring gear needle bearing out using the special tool and hydraulic press.

TOOL:
Oil seal driver

07947-SB00100 or
07947-SB0A100
(U.S.A. only)

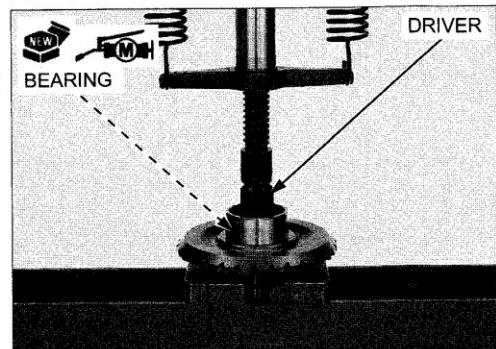

FINAL DRIVE

Install the snap ring.

NOTE:

- Install the snap ring with the chamfered edges facing the thrust load side.
- Make sure the snap ring is seated in the groove.

Apply grease to a new dust seal lips and install it.

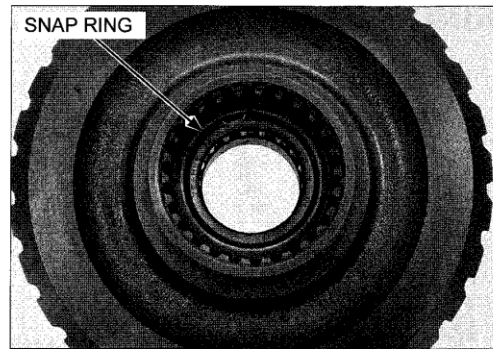

Place a new ring gear bearing onto the gear case cover with its marked side facing up.

Support the gear case cover horizontally and press the ring gear bearing using the special tools and hydraulic press.

TOOLS:

Driver	07749-0010000
Oil seal driver attachment, 80 x 96 mm	07ZAD-PNA0100 or 07VAD-P8A010A (U.S.A. only)

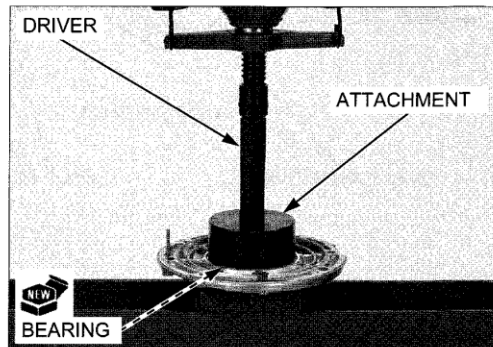

Place the ring gear shim and ring gear onto the gear case cover.

NOTE:

- When the gear set, pinion bearing, ring gear bearing and/or gear case has been replaced, use a 2.00 mm (0.079 in) thick shim for initial reference.

Support the bearing inner race with the special tool and press the ring gear using the hydraulic press.

TOOL:

Oil seal driver	070MF-MEG0300
-----------------	---------------

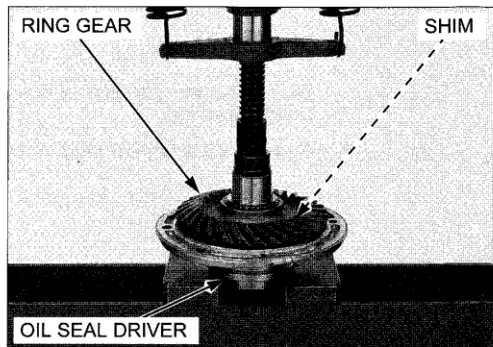

Measure the clearance between the ring gear and stop pin with a feeler gauge.

CLEARANCE: 0.30 – 0.60 mm (0.012 – 0.024 in)

Remove the ring gear if the clearance does not fall within the specification.

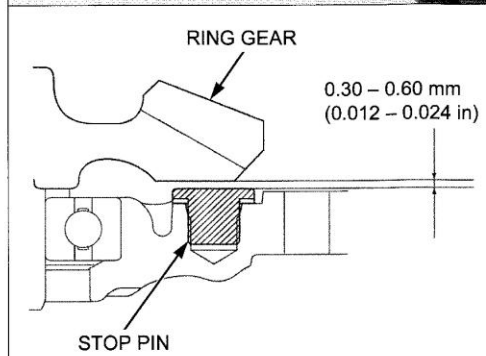
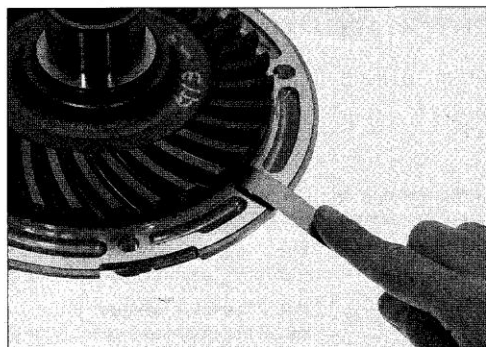

Be sure to wear heavy gloves when handling the heated gear case cover.

Heat the gear case cover to approximately 80°C (176°F). Heat the gear case cover evenly and slowly to prevent warpage.

NOTE:

- Do not heat small areas individually.

When the gear case cover is heated to the proper temperature, remove the stop pin by tapping the gear case cover.

Select a stop pin shim to obtain the correct clearance.

**SHIM THICKNESS: A: 0.10 mm (0.004 in)
B: 0.15 mm (0.006 in)**

Install the stop pin shim and drive in the stop pin into the gear case cover.

Reinstall the ring gear.

Apply grease to a new oil seal lips.

Install the oil seal until it is flush with the gear case cover surface.

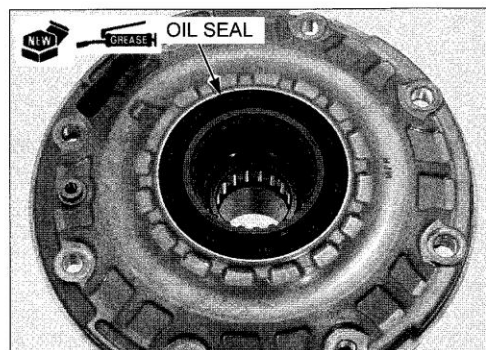
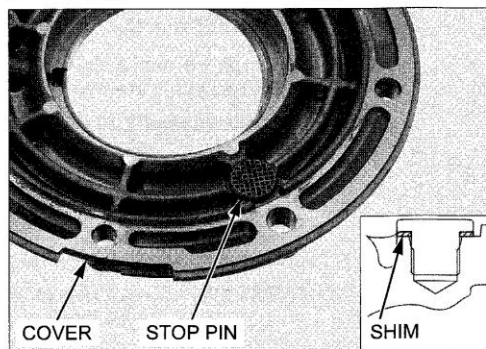

FINAL DRIVE

FINAL GEAR CASE ASSEMBLY

NOTE:

- When the gear set, bearing and/or gear case has been replaced, check the following:
 - Gear case backlash (page 14-9)
 - Tooth contact pattern (page 14-10)

Keep dust and dirt out of the case and cover.

Clean the mating surface of the gear case and cover, being careful not to damage them.

Apply liquid sealant (Three Bond 1216 or LOCTITE 5699) to the mating surface of the gear case.

Install the wave washer.

Install the gear case cover onto the gear case.

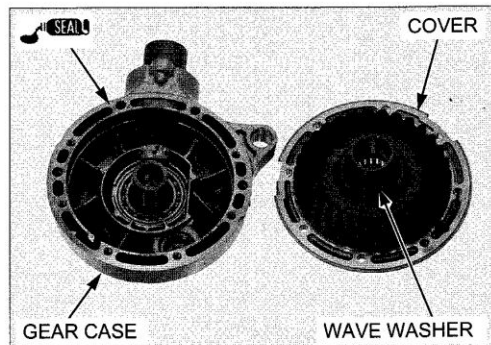

Apply locking agent to the final gear case cover 10 mm bolt threads.

Install and tighten the bolts in a crisscross pattern in several steps until the cover evenly touches the gear case.

Tighten the 10 mm bolts to the specified torque in several steps alternately.

TORQUE: 63 N·m (6.4 kgf·m, 46 lbf·ft)

Tighten the 8 mm bolts to the specified torque in a crisscross pattern in several times.

TORQUE: 26 N·m (2.7 kgf·m, 19 lbf·ft)

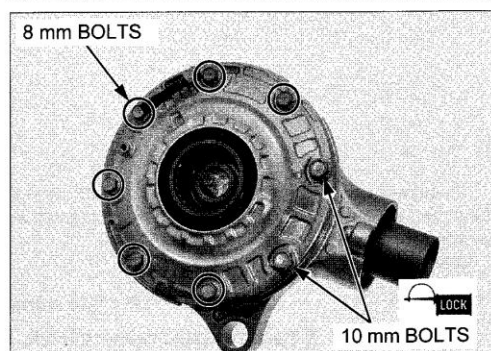

Check that the gear assembly turns smoothly without binding.

Measure the final drive gear assembly pre-load.

STANDARD: 0.2 – 0.4 N·m (0.02 – 0.04 kgf·m, 0.1 – 0.3 lbf·ft)

If the pre-load reading does not fall within the specification, check the bearings for proper installation.

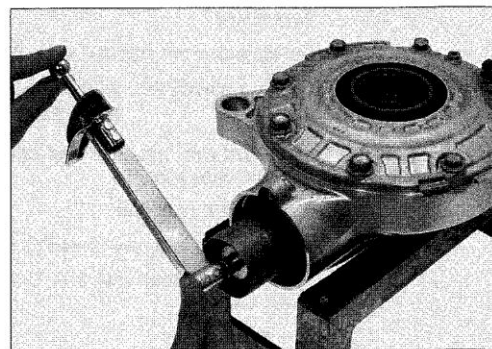

Install the dust guard plate by aligning its tabs with the gear case cover grooves.

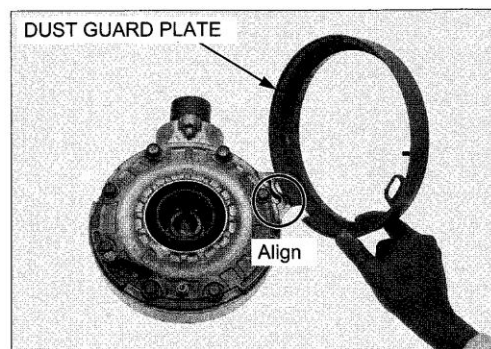

Turn the dust guard plate clockwise to lock.

Install and tighten the dust guard plate bolt to the specified torque.

TORQUE: 10 N·m (1.0 kgf·m, 7 lbf·ft)

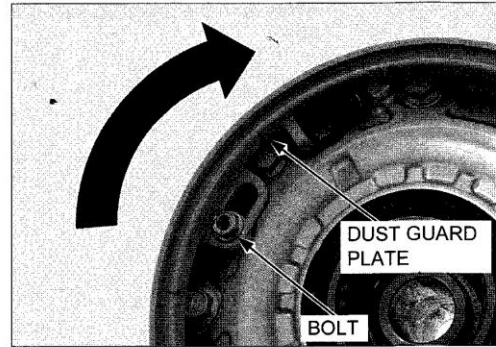

FINAL DRIVE INSTALLATION

Install the collar.

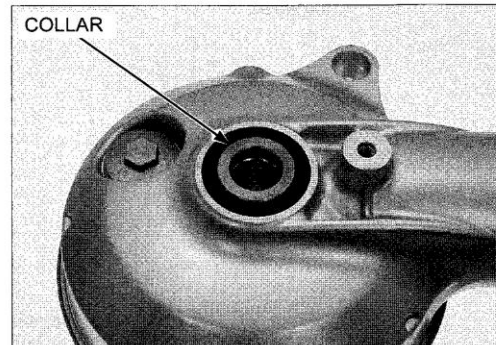

Install a new stopper ring into the drive shaft groove.
Install the spring into the drive shaft.

Apply 0.5 g (0.017 oz) of molybdenum disulfide grease to a new oil seal lip and install it onto the drive shaft.

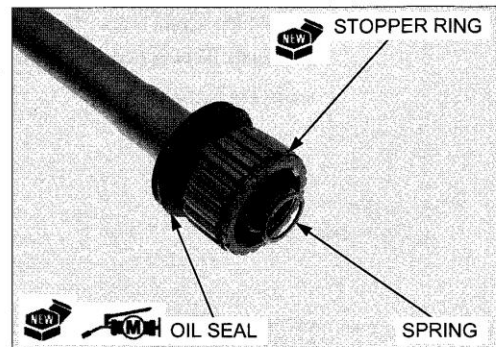

Apply 2 g (0.07 oz) minimum of molybdenum disulfide paste to the pinion joint splines.

Make sure the stopper ring is seated properly by pulling on the drive shaft lightly. Be careful not to damage the drive shaft oil seal.

Install the drive shaft into the pinion joint until the stopper ring seats in the pinion joint spline groove.

Apply 1 g (0.04 oz) of molybdenum disulfide grease to the universal joint side splines of the drive shaft.

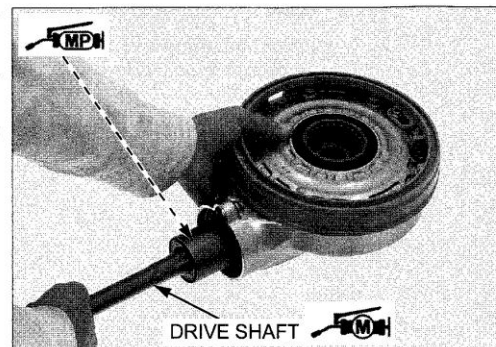

FINAL DRIVE

Make sure the universal joint is seated onto the output shaft.

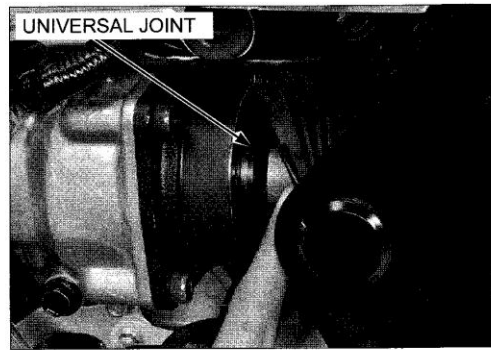

Insert the final gear case assembly into the swingarm and align the drive shaft splines with the universal joint splines.

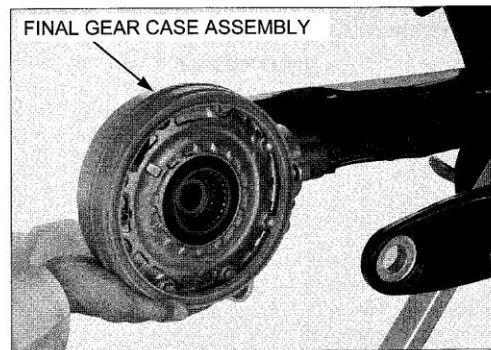

Align the bolt holes with the swingarm and final gear case assembly and install the layout bolt.

Tighten the layout bolt to the specified torque.

TORQUE: 21 N·m (2.1 kgf·m, 15 lbf·ft)

Install the rubber cap.

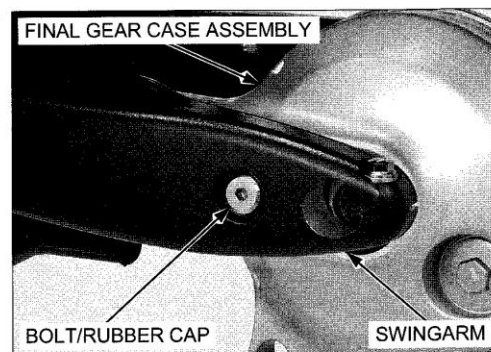

Apply molybdenum disulfide grease to the torque arm bushing outer surface and install it into the final gear case.

Install the torque arm, bolt and nut.

Tighten the nut, while holding the bolt to the specified torque.

TORQUE: 83 N·m (8.5 kgf·m, 61 lbf·ft)

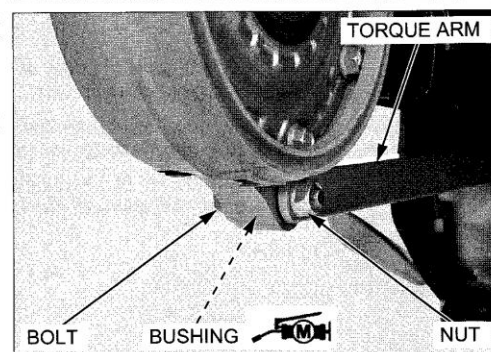

Install the drive shaft cover while aligning the following:

- Tab and swingarm lips
- Bosses and swingarm holes

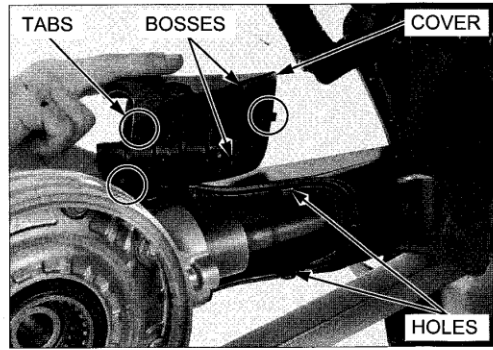

Install and tighten new socket bolts.

Install the rubber cap.

Install the rear wheel (page 16-13).

NOTE:

- When disassembling the final gear case, fill the recommended final drive gear oil (page 4-19).

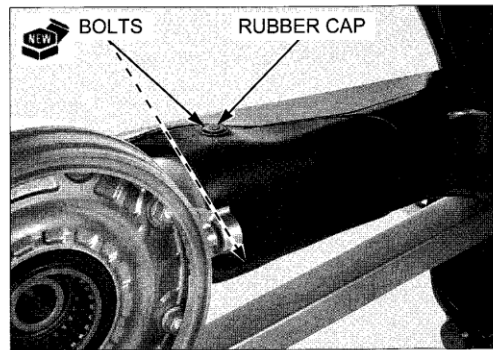

MEMO

